

ISOLATION SWITCH/
CIRCUIT BREAKER
OPERATOR
NORMAL POWER

OPERATOR
EMERGENCY POWER

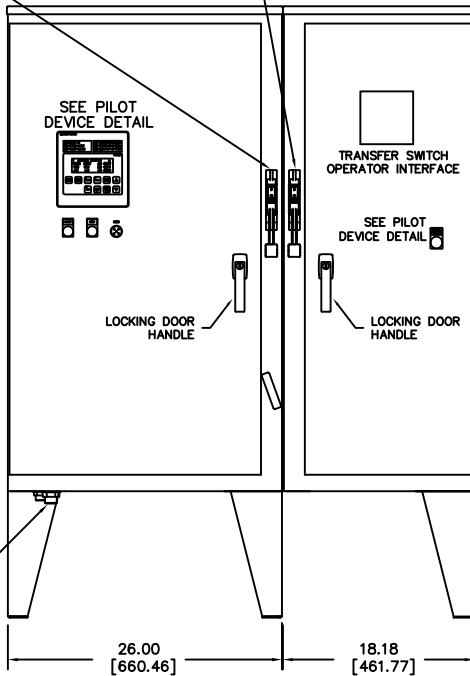

FRONT VIEW

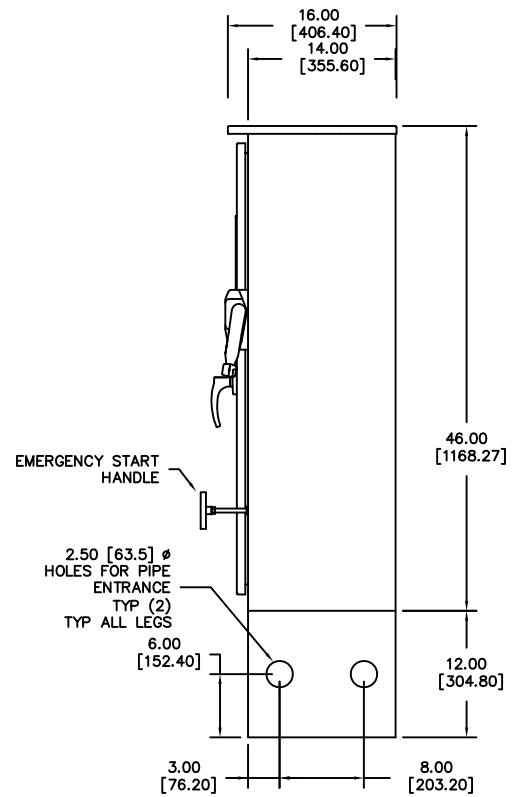

SIDE VIEW

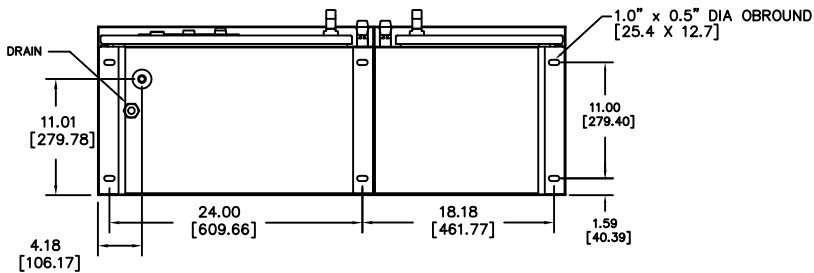

BOTTOM VIEW

PILOT DEVICE DETAIL

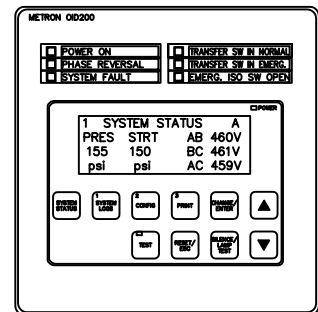

VOLTAGE	HORSEPOWER
200V	15-60 HP.
208V	15-75 HP.
230V	15-75 HP.
380V	15-125 HP.
460V	15-150 HP.

NOTES:
1. ALL DIMENSIONS IN INCHES AND MILLIMETERS ([]).

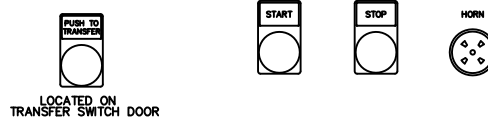

LOCATED ON
TRANSFER SWITCH DOOR

NEMA 2 ENCLOSURE.

DRAWN M.K.	3-20-05	METRON A Division of: Hubbell ICD, Inc. 4301 Cheyenne Dr., Archdale, NC 27263	
	CHECK R.L.		3-25-05
	APPD J.B.		3-25-05
ENCLOSURE DIMENSIONS MODEL MP300 WITH MTS 44"x46" CABINET ELECTRIC FIRE PUMP CONTROLLER		OPTIONS: CD33989F SCALE N.T.S. SHEET 1 OF 1	